



Science

PROPERTIES OF RIGID PVC SHUTTER REINFORCED WITH GLASS FIBER

Krisztina Roman^{*1}, Laszlo Roman²

^{*1} Institute of Ceramics and Polymer Engineering, University of Miskolc, Hungary

² Roman Kft, Hungary



Abstract

In this paper the PVC shutter with glass fiber composite mechanical properties can be examined. Based on previous researches the shutter needs more additives to give higher stability to the UV irradiation and degradation. These effect (degradation) are the main problems for these shading industry areas. The relationship between the structure and the additives of the rigid PVC were investigated. With the mechanical tests, such as tensile-, bending-, impact- and hardness test the structural of the composite can be determined. The composites properties compared to a simple rigid PVC property. In the results of the mechanical tests, the ultimate strength and the belonging deformation were decreased compared to the simple PVC properties.

Keywords: Rigid PVC; Glass Fiber; Mechanical Properties; Shutter Components.

Cite This Article: Krisztina Roman, and Laszlo Roman. (2018). "PROPERTIES OF RIGID PVC SHUTTER REINFORCED WITH GLASS FIBER." *International Journal of Research - Granthaalayah*, 6(4), 174-178. <https://doi.org/10.29121/granthaalayah.v6.i4.2018.1640>.

1. Introduction

The poly (vinyl chloride) is world-widely used thermoplastic polymer. It can be use in different area due to the excellent properties [1]. These areas are the building-, packaging or medical industry. Also it can apply coatings and shielding techniques in the building industry [2]. From rigid PVC made are octagonal tube, side/guide rail, exterior stop side/end cap and of course the PVC slats [3]. The processing of PVC use UV stabilizer, which especially give special properties of rigid PVC. The product can use in area of outside production. The PVC product has a long service life, good thermal properties and excellent UV-stabilized and weather resistant. Without any stabilizer the product suffers from degradation, discoloration and deformation [4].

Fiber reinforced blends are widely used because it has some special properties, such as excellent process ability, stiffness, ease of miscibility [5]. The fibers can be classified by natural and synthetic fiber [6]. Nowadays the commonly used synthetic fibers are the carbon-, aramid-, glass- or nylon fiber. Particularly used material is the glass fibers, which has positive and negative aspect also. The advantages are the good physic mechanical-, absorption and insulation properties,

excellent corrosion resistance and their moisture repellency [5]. The negative aspects are the difficult recycle and the glass fiber shatters the extruder tools and screw. Glass fibers were initially used for considerable. Small amount of glass fibers has positive effect to the composite, improved increase mechanical and structural properties. Studies have found that the glass fibers with different size (short, long) are found no positive effect. The short fibers are increasing the impact strength of the blend [7]. The short glass fiber was used to enhance the dimensional stability of rigid PVC. Some studied considered that the mixtures with longer glass fibers exhibit better thermal properties than those which blends with included shorter glass fibers [8].

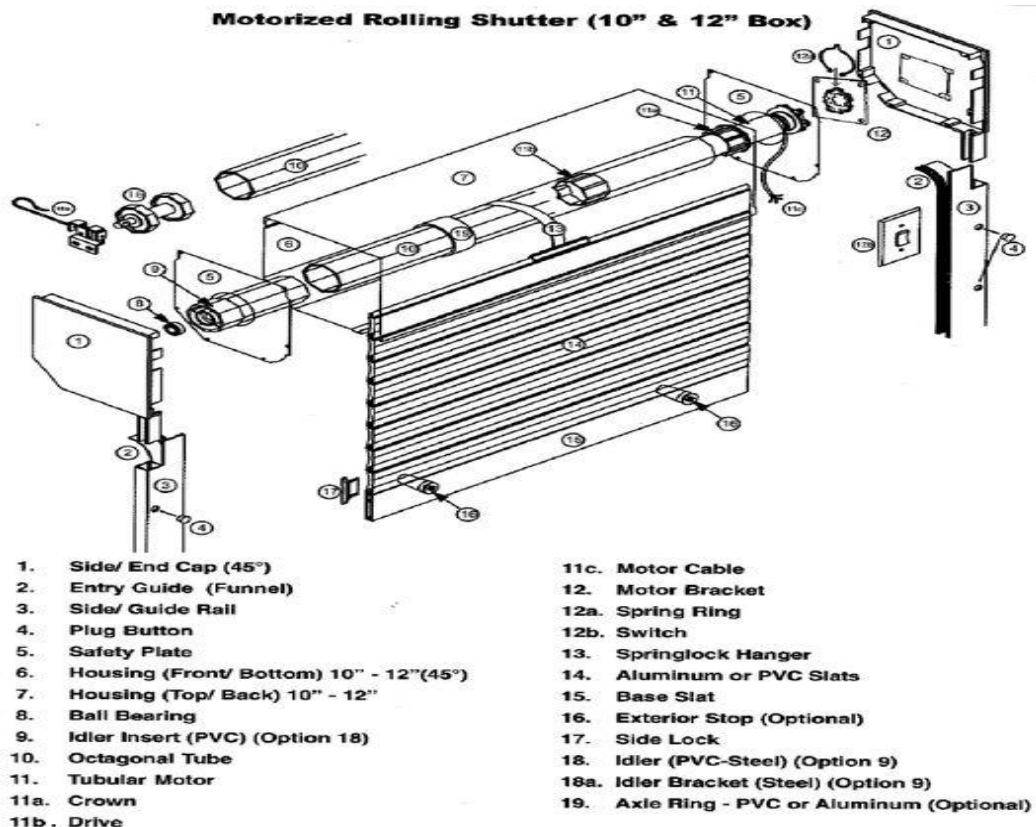

Figure 1: Optional rolling shutter construction [9]

2. Materials and Methods

The raw material is a rigid PVC compound from Roman Kft. company. Glass fibers purchased from a local company and use for the present work as well. The fibers generally contain oxides of silicon, calcium, aluminum, magnesium and boron [8]. Ingredients of the rigid PVC composites are commercial products; PVC powder, stabilizer, external - and internal lubricants, ground CaCO_3 filler. The amount of glass fiber content was 3.5 phr in the composite. The rigid PVC density was 1.6747 g/cm^3 . The blend's density was 1.6838 g/cm^3 .

2.1. Sample Preparation

The samples preparation has some problems. First and foremost, used high-speed mixer and it destroys the glass fiber structure. The additives appearance modified, it looks like natural wool.

The mixing time was only 2 minutes. The second problem was the extrusion. The extruder screw was difficult to elaborate this glass fiber, which is similar to the wool. The glass fiber wasn't spread well into the PVC base mixtures. For the tests different types (size) of specimens from rigid PVC composite were prepared. The specimens were die cut with pneumatic punching machine.

2.2. Hardness Test

We are usually using Shore D equipment for harder materials to examine the hardness values [10]. The test was measured with Zwick/Roell Shore D equipment according to ISO 868 standard. The values of the hardness were calculated as an average of 20 points.

2.3. Tensile and Flexural Test

The tensile and flexural test was performed by INSTRON 5566 testing machine, according to tensile: ASTM D638-10 and flexural ISO 178:2010 standard. The measurements speed was 100 mm/min at room temperature ($23\pm 1^\circ\text{C}$).

3. Results and Discussions

3.1. Hardness Test

From the test result -*Table 1*-, it can be seen that the glass fiber does not mix well in the basic matrix. In spite of the similar density values, it was not affected the hardness. The composites softer than the origin sample.

Table 1: Results of hardness test

Samples	Mean
Rigid PVC	77.3 ± 0.89
PVC/glass fiber	73.5 ± 1.4

3.2. Tensile Test

The result of the evaluation was suggested that the glass fiber did not strengthen the material structure. The tensile strength was lower than the original samples strength. Fig. 2 show that the elongation at break strongly decreased by the glass fiber.

Table 2: Results of tensile test

Samples	Maximum Tensile stress [MPa]
Rigid PVC	35.30 ± 1.8
PVC/glass fiber	35.20 ± 0.88

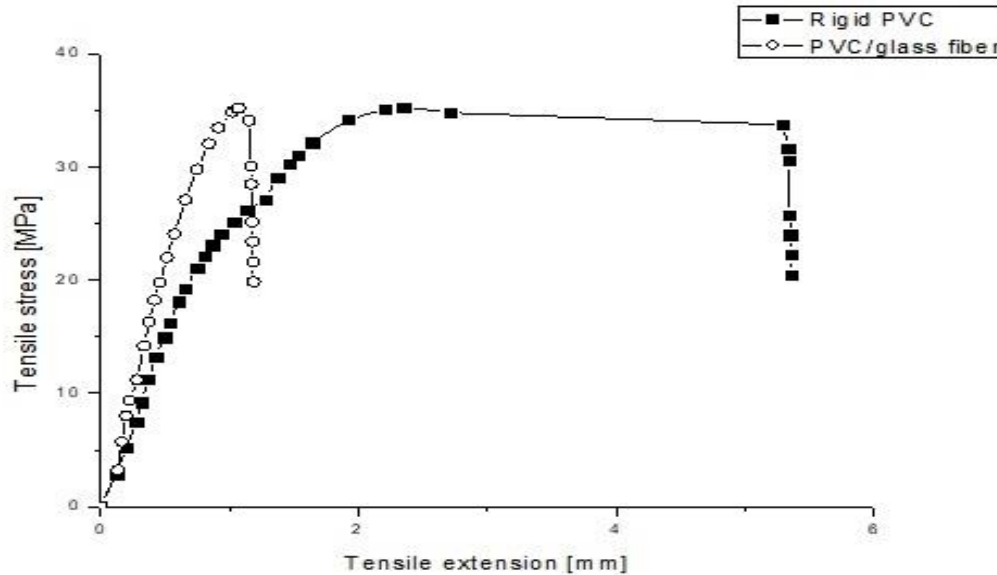

Figure 2: Result of Tensile test

3.3. Flexural Test

The bending test results were similar to the tensile test. The flexural strength and modulus is higher for the base mixture. The glass fiber was not effective in the blend structure.

Table 3: Results of flexural test

Samples	Maximum Flexure stress [MPa]
Rigid PVC	57.89±1.6
PVC/glass fiber	52.26±1.45

Table 4: Results of flexural modulus

Samples	Modulus [MPa]
Rigid PVC	3150.5±36.0
PVC/glass fiber	3081.7±112.63

4. Conclusions & Recommendations

The glass fiber reinforced PVC composite mechanical properties were determined. The aim of the research was to prepare a good miscible mixture and understand the composite final structure. The all mechanical properties of the composite give lower mechanical strength compared to simple rigid PVC specimens. This evidenced is the structure deterioration. The reason for the weak strength was the mixing and processing. This method is not suitable for the production of high quality and excellent properties composites.

References

- [1] W. V. Titow; PVC Technology, Fouth Edition, England, 86-103, 1984
- [2] Michael Schiller: PVC Additives, 2010, 46-62

- [3] Roman Kft. <http://www.romankft.hu/> (20.04.2018)
- [4] <https://solutions-in-plastics.info/en/products/construction-plastics/pvc-polyvinyl-chloride/> (23.04.2018)
- [5] Ruhul A. Khan, Nusrat Sharmin and et.: Comparative Studies of Mechanical and Interfacial Properties Between Jute Fiber/PVC and E-Glass Fiber/PVC Composites, *Polymer-Plastics Technology and Engineering* 50: 153-159, 2011
- [6] K.John and S. Venkata Naidu: Sisal Fiber/Glass Fiber Hybrid Composite: The Impact and Compressive Properties, *Journal of Reinforced Plastics and Composites* 2004 23: 1253
- [7] S. Tungjitpornkull, N.Sombatsompop: Processing technique and fiber orientation angle affecting the mechanical properties of E-glass fiber reinforced wood/PVC composites, *Journal of Materials processing technology* 209 (2009) 3079-3088
- [8] Murtatha Jamel: The effect of E-glass fibers and Phlogopite Mica on the Mechanical properties and Dimensional Stability of Rigid PVC Foams, *Theses and Dissertations, University of Wisconsin – Milwaukee*, 2015
- [9] Doors and Chairs Ideas, <http://www.mehtaphornyc.com/roller-shutter-door-parts-Y234643/roller-shutter-door-parts-d48-on-simple-home-design-planning-with-roller-shutter-door-parts/> (20.04.2018)
- [10] <http://www.ptli.com/testlopedia/tests/durometershore-d2240.asp> (23.04.2018)

*Corresponding author.

E-mail address: polkrisz@ uni-miskolc.hu