



Science

IMPLEMENT AN EXTENSION CORD POWER SOCKET WITH EMERGENCY LIGHTING AND VOICE CONTROL LIGHTING FUNCTIONS

Ching-Sung Wang ^{*1}, Chien-Wei Liu ², Teng-Hui Wang ³

^{*1} Department of Electronic Engineering, Oriental Institute of Technology, Taiwan

² Department of Information Management, St. Mary's College, Taiwan

³ Department of Computer Science, National Taiwan Science University, Taiwan



Abstract

Conventional power sockets are equipped with an extension cord. Even with anti-overload devices, incidents of accidental discharge or damage to electrical appliances may still incur due to external factors. To address this problem, this study integrated the voice control and lighting functions to the design of the power socket with an extension cord. The proposed design is space-efficient and versatile, and can be used in living rooms, bedrooms, and other places having electrical appliances. The proposed design also integrated emergency lighting and flashlight functions, so as to expand the practicality and safety of the power socket.

Keywords: Power Socket; Extension Cord; Emergency Lighting; Overload Device; Flashlight.

Cite This Article: Ching-Sung Wang, Chien-Wei Liu, and Teng-Hui Wang. (2017). "IMPLEMENT AN EXTENSION CORD POWER SOCKET WITH EMERGENCY LIGHTING AND VOICE CONTROL LIGHTING FUNCTIONS." *International Journal of Research - Granthaalayah*, 5(8), 228-235. [10.29121/granthaalayah.v5.i8.2017.2218](https://doi.org/10.29121/granthaalayah.v5.i8.2017.2218).

1. Introduction

Under the awareness over energy saving and environmental protection in recent years, light-emitting diodes (LEDs) have been widely. Compared to conventional light bulbs, LEDs have higher efficiency and lower power consumption. Their smaller size also greatly expands their range of application. Thus, the development of LEDs has driven the LED industry, and may change the use of lighting in the future. LEDs are often used on technological products in everyday life. This study integrated LED lighting to household devices with an extension cord, in order to improve the safety and convenience of devices that could use LED lighting [1].

In the introduction, be mindful of the following:

- **Context:** It is important to communicate to the reader a clear picture of the overall context of your research project. The way you write the beginning of your paper lays the

foundation (weak or strong) for the credibility and trustworthiness of your results and conclusions.

- *Use storytelling*: Instead of telling about your setting, illustrate it for the reader using stories and anecdotes taken from your notes, reflections, and data. Introduce major players in your analysis and results.
- *Include active and layered description*: Use multiple data sources to illustrate the setting and story behind the research. It must be clear to the reader that you are thoroughly immersed and engaged in your setting, and are therefore qualified to make credible analyses and interpretations. By referring to some data here you signal to the reader prior to the rest of the paper what type of research this is and how data were generally collected.
- *Your story*: It is also important to communicate to the reader a clear picture of yourself as the researcher and how your own biases and experiences, and assumptions not only influence the study but also provided the fodder for your critical question. This may be woven into your illustration of context by including your own thoughts and memories. If there are key quotes that tell your story in another's words, consider including the quote in this section. Make it clear how you arrived at your critical question.
- *Your critical question*: Bring your narrative to a climax in which you lay out your critical question in detail. Explain briefly what your action(s) consisted of. Tell briefly what your conclusions look like (don't try to keep the reader in suspense).

In summary, an Introduction should have:

- Clear and explicit introduction of the problem being investigated.
- All problems should be accurately and clearly defined.
- Literature review conveys what is known about the topic, and possible research gaps.
- Literature used in review should be appropriate (i.e., from a peer reviewed journal).
- Logical presentation of ideas (i.e., no illogical jumps or omissions).
- Research proposed is discussed in the context of what is already known.
- Study Framework and Significance of the Study shall be included here.
- Hypotheses are stated (if applicable).

2. System Design

In the course of circuit design, understanding the basic requirements and rules of the chip is essential. Fig. 1 shows the overall circuit plan. After AC is input and converted into DC via a transformer, the output voltage is DC5V, while the output current is 1A. It supplies power to all sensors and circuits. The power display circuit is directly powered by the battery in the charging circuit.

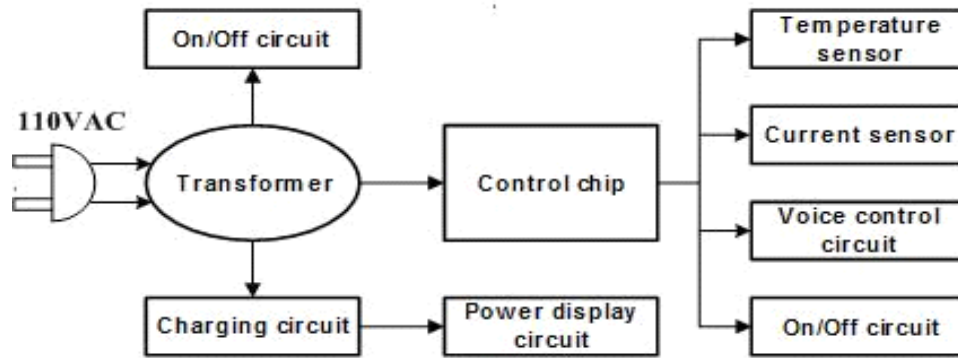

Figure 1: Circuit system

3. Circuit Function

3.1. Electricity Switch Circuit

Fig. 2 illustrates the electricity switch circuit that is a self-contained function. To prevent a blackout, a battery is required for switching. Therefore, in the design of the circuit, the charging circuit is also included.

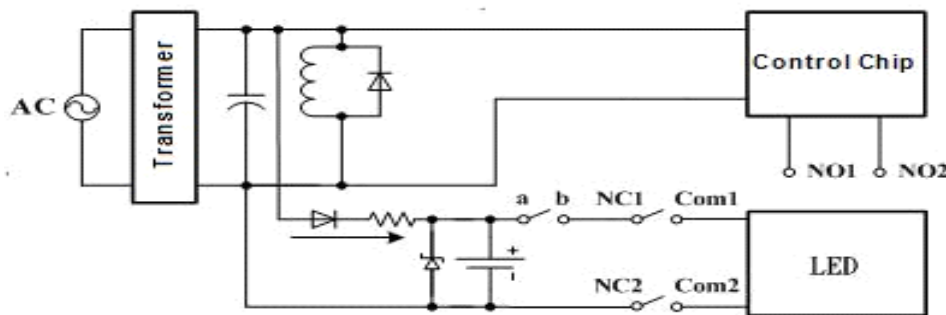

Figure 2: Electricity switch circuit

From the perspective of emergency lighting, the two circuits should be inseparable. The circuits [2] and [3] mainly adopt the switching feature of Relay (RY). Take one switch for instance, there are three points: Common (Com), Normally Open (NO), and (Normally Close (NC). The RY of HRS2H-S-DC5V, in Fig. 3, has two sets of switches. Com 1 and Com 2 of the two sets of switches are both connected to the positive and negative ends of the LED board, while NC1 and NC2 are both connected to the positive and negative ends of the battery. Lastly, NO1 and NO2 are connected to the main control board.

The two ends of the coil are connected to the DC voltage converted from the AC. In other words, if there is no voltage between the two ends, then Coms would be attracted by NCs. Hence, the positive and negative ends of the LED board are connected to those of the battery, so that the LED board gives out light. If there is voltage between the two ends, then Coms would be switched to NCs, thereby switching the positive and negative ends of the LED board to the main control board. Thus, the LED board does not give out light.

3.2. Charging circuit

Considering the volume and complexity, the charging circuit is often designed in a simple manner [4] [5]. A diode is used to adjust the direction of the current. The resistor is a current-limiting resistor used to buffer the current passing by. This study used resistance of 330 (Ohm) and adopted a 4V Zener diode to stabilize the voltage. As shown in Fig. 3, if the input voltage is lower than the battery voltage, it is impossible to charge. Therefore, the input voltage is kept at 4V.

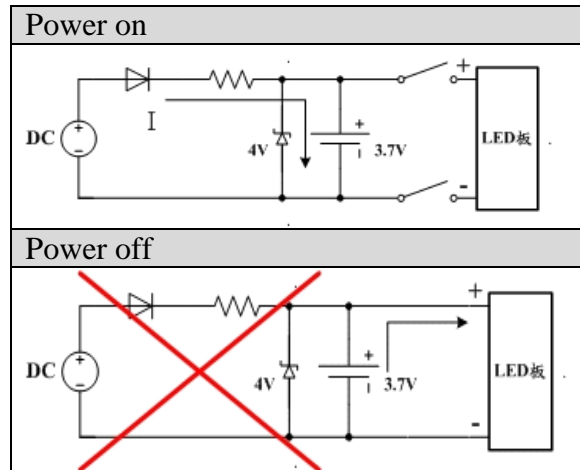

Figure 3: Schematic diagram of the function of the charging circuit

3.3. Power Display Circuit

The power supply of the power display circuit [6] comes from the battery, which is mainly designed based on the reverse bias characteristic of the Zener diode, as shown in Fig. 4. When the terminal voltage (V_{ab}) is smaller than the voltage (V_z) of the Zener diode, the circuit is considered an open circuit, because the Zener diode does not reach the collapse point. The current (I_z) passing by is 0A.

Four LED lights are used to display power, as shown in Fig. 6; hence, the value of the Zener diode must depend on the input voltage. For instance, if the input voltage is 5V, then V_{z1} could be 4.8V, while V_{z2} would be 3.6V, and so on.

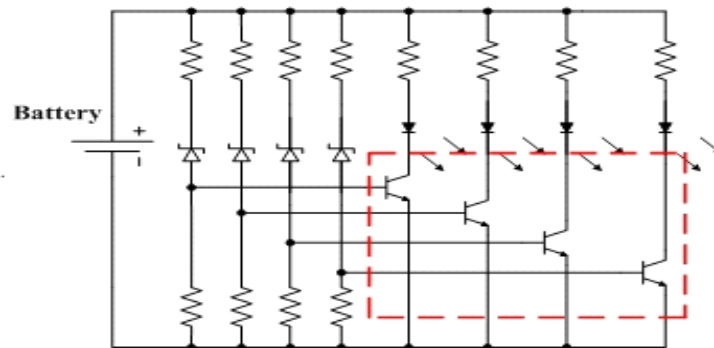

Figure 4: Power display circuit

3.4. Temperature Sensor

As for temperature sensing, this study employed the AD590 temperature sensor, which is for analog output. Its output current has a linear relationship with the rise or fall of temperature. When the temperature increases by 1 degree, the output current rises by 1uA. As the benchmark temperature for the output current is -273°C , when the indoor temperature hit 25°C , the output current (I_o) = $273 + 25 = 298\mu\text{A}$.

3.5. Power Display Circuit

The most common currents of average power sockets with extension cords are 11A and 15A. As shown in Fig. 5, this study adopted the 20A Hall current sensing module [7]. The benchmark output voltage of this module is $V_{cc}/2$. When the input voltage is 5V and the input current is 0A, the output voltage is 2.5V.

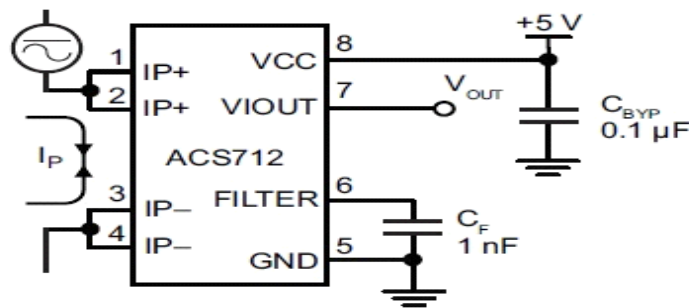

Figure 5: 20A Hall current sensing module

3.6. Power Display Circuit

This study adopted 943-1C-5DS RY in the switching circuit designed, as shown in Fig. 6. Its rated current is 12A. The AC used in this system is 11A. Points a, b, c, and d are for input. Their signals are controlled by chip CC2530.

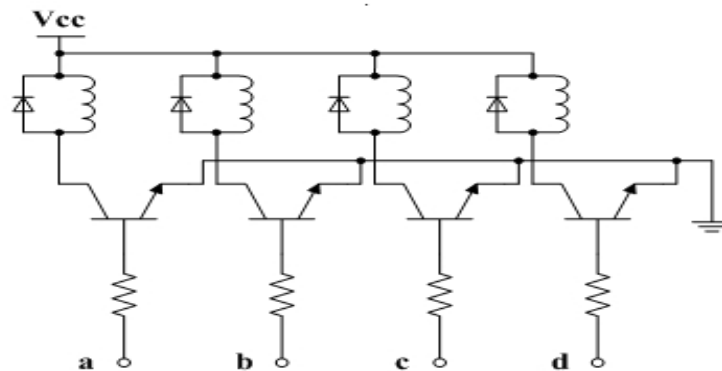

Figure 6: Switching circuit

3.7. Power Display Circuit

The voice control circuit is the peripheral circuit of the main control board with a condenser microphone as its input. When a sound wave is the input, the vibration film vibrates. As the substrate is fixed, the distance between the vibration film and the substrate changes along with sound waves, thus altering the changes of capacitance value and voltage.

4. Chip Design and Planning

As mentioned earlier, the chip used in this study is CC2530, which has been modularized. Hence, for the design of the main control board, it is only necessary to plan the input power and pins [8-10]. As shown in Fig. 7, points a, b, c, and d are connected to the switching circuit, while NO1 and NO2 are connected to the electricity switch circuit. Fig. 3 and Fig.8 show the connection points.

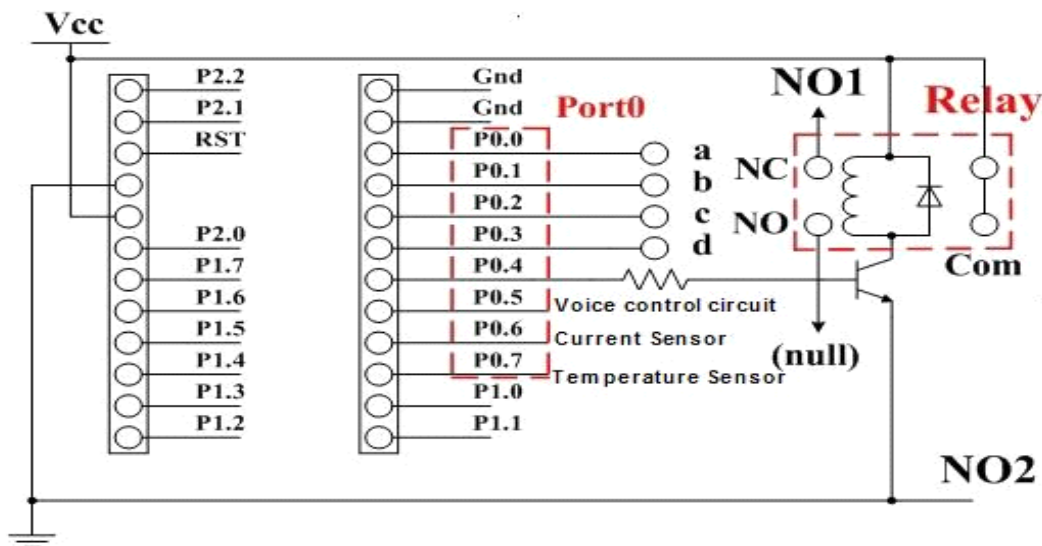

Figure 7: Circuit of the main control board

This system uses the built-in RF wireless module of CC2530 and 12bit-ADC (Analog-to-Digital Converter), which can be implemented through programs. As shown in Fig. 8, P0.0-P0.4 are output ends, controlled by high state (1) and low state (0), while P0.5-P0.7 are output ends. Except for the voice control circuit having a high state (1) and low state (0) input, the inputs of the two sensors are both direct voltage. In other words, the values of P0.6 and P0.7 should be read through 12bit-ADC.

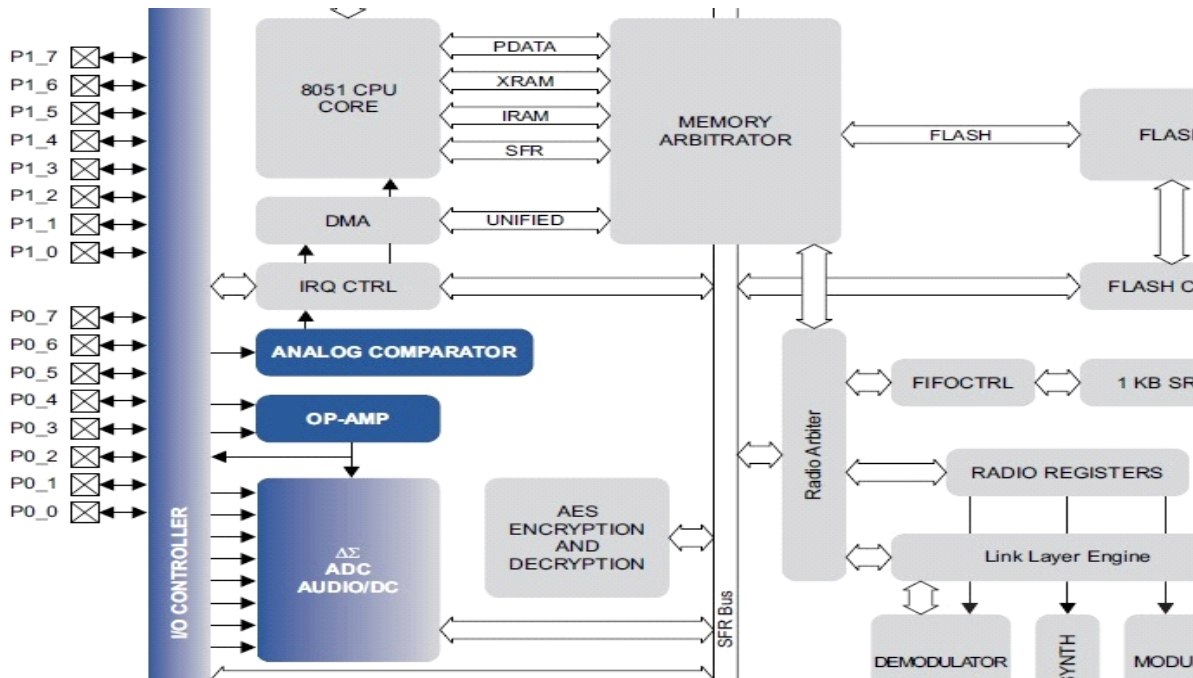

Figure 8: CC2530 block diagram

5. Design Functions and Results

In the introduction, be mindful of the following:

- ***Emergency lighting:*** When power is off, LED lights turn on automatically.
- ***Pluggable power socket:*** This design is an extension function of emergency lighting, which is convenient for users. When power is off, the power socket with an extension cord could be moved to any place.
- ***Voice control lighting:*** If a user is in the dark, he/she can turn on or off the LED lights by clapping his/her hands.
- ***Temperature monitoring:*** If the ambient temperature of the power socket with extension cord is higher than 60°C, then LED lights can flash to warn the user. If it is higher than 90°C, then the socket can automatically turn the power off. During other times, the user can see the current temperature via the software interface.
- ***Display of current and power:*** Via the software interface, the user can learn see the present current and wattage values of the power socket with extension cord.
- ***Wireless switch control:*** Via the software interface, the user can turn on and off each socket.

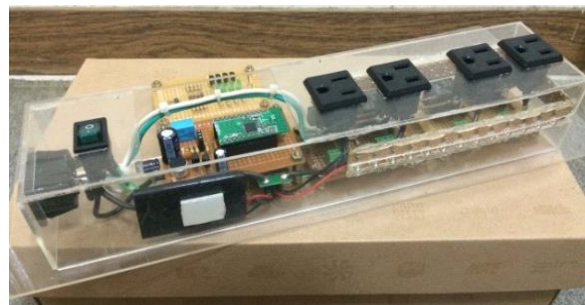

Figure 9: Entity

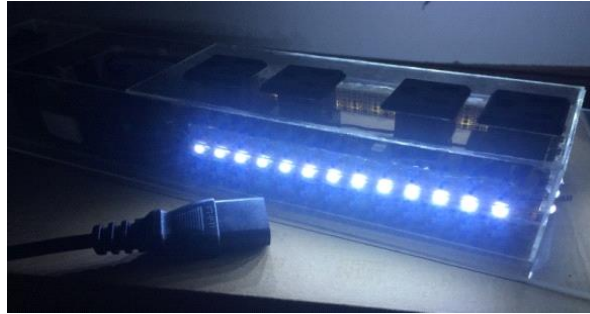

Figure 10: Power off

6. Conclusion

Home electronic products have become increased popular. The issue of safety thus becomes important in the process of product research and development. This study integrated LED lights and power socket with extension cord, and developed additional functions for home safety. The proposed design is expected to present a new direction of home appliances, as well as improve home safety.

References

- [1] Hsu, Y. H. and Liao, C. H. Comparison on Light-emitting Diode and Tungsten Lamp, Electronics Department, Taipei Songshan High School of Agriculture and Industry, 2009.
- [2] Su, H. Y. The Effect of Temperature on High Voltage LEDs and the Application with Desk Lamp, Department of Electrical Engineering, National University of Tainan, 2012.
- [3] Lu, R. C. Design and Application of High Power LED Driven Circuit, Wunan Publishing, 2009.
- [4] Chen, W. C. and Chen, K, Design and Implementation of a ZigBee Sensor Network Application Programming Interface, National Chengchi University, 2011.
- [5] ZigBee Forum <http://bjbcycu.blogspot.com>.
- [6] Kuo, P. H., Yang, W. T. and Su, K. C. Precautions and Safety Information on the Accidental Discharge of Cables, National Tainan Senior Marine Fishery Vocational School, 2010.
- [7] Li, P. H. and Hsu, C. Y. Know How Much Electricity You Used—Current Sensing System, Taipei Municipal Nei-Hu Vocational High School, 2009.
- [8] Huang, C. H., Implementation of Driving Circuit for High Brightness LEDs, Department of Electrical Engineering, National Cheng Kung University, 2009.
- [9] Chen, S. N. Trend Development and Strategic Analysis of Taiwan LED Lighting Industry, National Tsing Hua University, 2009.
- [10] Chen, Y. S. Implementation of A Phase-shifted PWM Dimmer for LED Indoor Lighting, Department of Electrical Engineering, National Kaohsiung University of Applied Sciences, 2009.

*Corresponding author.

E-mail address: ff020@ mail.oit.edu.tw