



DESIGN AND SIMULATION OF AUTOMATIC POWER FACTOR CORRECTION FOR INDUSTRY APPLICATION

Ararso Taye^{*1}

^{*1} M.Tech, Electrical Engineering Department, Parul University, India



Abstract:

In the present technological revolution power is very precious. So we need to find out the causes of power loss and improve the power system. Due to industrialization the use of inductive load increases and hence power system losses its efficiency. So we need to improve the power factor with a suitable method of automatic power factor correction. This study undertakes the design and simulation of an automatic power factor correction that is developed using arduino microcontroller ATmega328 Automatic power factor correction device reads power factor from line voltage and line current. This time values are then calibrated as phase angle and corresponding power factor. The display used was 4X16 liquid crystal display module. The motherboard calculates the compensation requirement and accordingly switches on different capacitor banks will run. This automatic power factor correction technique can be applied to the industries, power systems and also households to make them stable and due to that the system becomes stable and efficiency of the system as well as the apparatus increases. The use of microcontroller reduces the costs and the customers become beneficial according to the simulated output because the power factor of the specific selected industry is corrected from 0.66 to 0.92 improved value.

Keywords: Power Factor; Active Power; Reactive Power; Complex Power; Current Transformer; Potential Transformer; Capacitor Bank.

Cite This Article: Ararso Taye. (2018). "DESIGN AND SIMULATION OF AUTOMATIC POWER FACTOR CORRECTION FOR INDUSTRY APPLICATION." *International Journal of Engineering Technologies and Management Research*, 5(2), 10-21. DOI: <https://doi.org/10.29121/ijetmr.v5.i2.2018.142>.

1. Introduction

The power factor of an AC electric power system is defined as the measurement of the degree to which a given load matches that of a pure resistance. It is a ratio of average power of any given load to average power of a resistive load for same voltage and current magnitude and its value is also between 0 and 1. Active power is the actual amount of the power being used, or dissipated, in a circuit is called active power (P), and it is measured in watts. Active power is the product of the sinusoidal voltage and current wave form. Reactive power is the power consumed in the ac circuit because of the inductive and capacitive field. The unit used for measuring reactive power is KVAR [1]. Apparent power is the combination of the active power and reactive power. It is the product of a circuit voltage and current without reference to phase angle. Apparent power(S)

is measured in the unit of volt-amps (VA). It is greater than the active power and reactive power. Because of the reactive power is the energy stored in the circuit and it is negative or the current lags the voltage by phase angle goes back to the source or due to mismatched load that distorts the generated wave form the power source. A load with a power factor unity is the purely resistive load, because the sinusoidal voltage and sinusoidal current wave form is in phase or the phase angle difference between the voltage and the current is zero [2]. A poor power factor can be the result of a significant phase between the applied voltage and the current at the load terminals or it can be due to a high harmonic content or distorted (discontinuous current wave form). The poor load current phase angle can be generally the result of inductive loads such as induction motor, power transformers and lighting ballasts. A distorted current wave form can be the result of rectifier, variable speed drive, switched mode power supply and other electric loads. Low power factor loads increases losses in power supply and distribution system and it increases the cost in electricity in bills. Since the purely resistive ac circuit of the sinusoidal voltage and current waveforms are in phase; changing polarity at the same instant in each cycle circuits containing purely resistive heating elements such as filament lamps and cooking stoves have a power factor of 1.0. Circuits containing inductive or capacitive elements such as lamp ballasts and motors often have a power factor below 1.0[3]. Reactive power compensation has been increasing, mainly because of the way in which energy supplier charge a customer for reactive power. In addition to the above explanation, the energy price is growing, what force the industry plants and individual customers to minimize energy consumption, including reactive power. Generally there are solutions that allow handle the problem of reactive power compensation. The first one is reactive power compensator using power factor capacitors. This is very important compensating device, due to economic reasons and they are very cheap comparing with active filters by means of electric motors [4].

To be successive with work they accomplish the main thing is power uses for any organization mean that whether governmental or non-governmental the key problem always they face are the power quality. This occurs due to the loss of power happen on transmission and also due to improper distribution of the system especially in industry. This situation presents problem of poor power factor by the result of either a significant phase difference between the voltage and the current at the load terminals. Due to the occurrence of Poor power factor the cost of the electricity bills in the customer's increases.

In the present scenario of technological revolution it has been observed that the power is very precious. The industrialization is primarily increasing the inductive loading, the inductive loads affect the power factor so the power system losses its efficiency (by: Prof. S. Ghosh, 2007). The automatic power factor correction device is a very useful device for improving efficient transmission of active power. If the consumer connect inductive load, then the power factor lags, when the power factor goes below 0.97(lag) then the electric supply company charge penalty to the consumer. So it is essential to maintain the power factor below with in a limit. Automatic power factor correction device reads the power factor from line voltage and line current, calculating the compensation requirement switch on different capacitor banks [5].

The current drawn by inductance lags the voltage while the one by capacitance leads the voltage. Almost all industrial loads are inductive in nature and hence draw lagging wattles current, which unnecessarily load the system, performing no work. Since the capacitive currents is leading

in nature, loading the system with capacitors wipes out them. The lower the power factor, the worse the situation becomes from the supply authorities' viewpoint. Accordingly, consumers are encouraged to improve their load power factor and in many cases are penalized if they do not. Improving the power factor means reducing the angle of lag between supply voltage and supply current. Power factor correction brings the power factor of an AC power circuit closer to 1 by supplying reactive power of opposite sign, adding capacitors or inductors which act to cancel the inductive or capacitive effects of the load, respectively [6].

1.1. Power triangle

The cosine of the angle blow is also equal to KW per KVA so you can think of the power factor as the ratio of real power to what you measure with a volt and amp meter (apparent power). If they are equal, then your power factor is one.

Reactive power is not a problem for a motor and is required for its operation. It is a problem for the electric utility company when they charge for KW only. If two customers both use the same amount of real energy but one has a power factor of 0.5, then that customer also draws double the current [7-9].

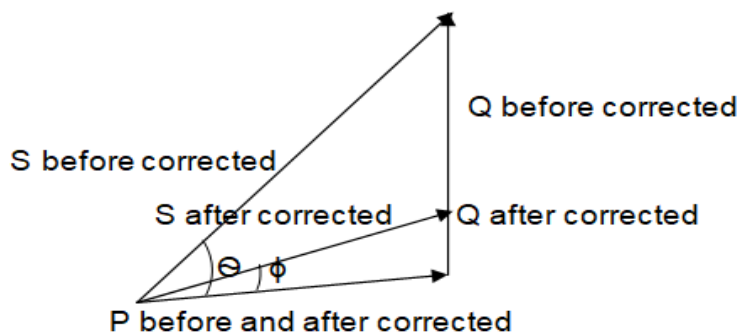

Figure 1: Power angle circuit

The main objective of the proposed system is design of automatic power factor correction using microcontroller software. Specifically;

- To design an automatic power factor correction using an arduino micro-controller in C-language for improving the poor power factor by adding parallel capacitors to the motor terminals.
- To develop an automatically corrected power factor to establish design parameters.
- To simulate the established control concepts relative to its corresponding input and output relationship and control frame work.

This study significantly provides an important study results for cost effective, reliable and faster power factor corrector. Thus the result of designing power factor corrector for small industrial enterprises will have the following significances.

- It minimizes value of reactive power in the power triangle by connecting the capacitance of the capacitor to the motor terminals to make the apparent and real power to become in phase.
- It reduces of voltage drop in long cables.
- It minimizes the reactive power and phase angle difference between the sinusoidal voltages and current wave shapes. This can result to decrease the power consumption and power losses, the cost will also be less than the recent.
- It improve low power factor by using power factor correction and this method is important in minimizing the wasted energy.
- It improves efficiency of a plant and reducing the electricity bill but not necessary to reach power factor unity.

2. Materials and Methods

In this context the design of the automatic power factor correction, the procedures used in the design, the material and data analysis based on specific place are studied. In the past era when technology is not advanced many industrial organization face problem to perform their task in efficient way. One reason for this problem is the use of small power factor which has great affect for machine to work properly (need large maintenance). In this study we took one specific area at Debre Markos, Ethiopia, Selam Flour Factory to overcome this problem. This factory uses small power factor of 0.66, now the power factor will be corrected by connecting capacitor bank parallel with the load. For this work the collected data from Selam Flour Factory is shown table 1. As in the table, based on the collected data the design for correcting the system power factor was done.

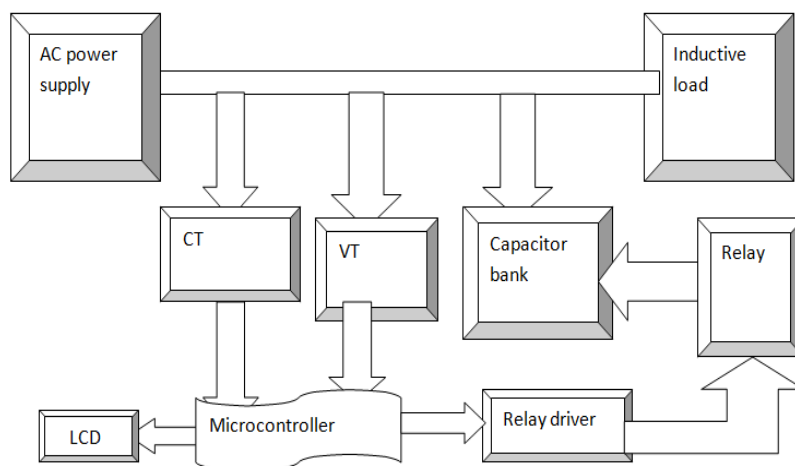

Figure 2: The functional block diagram for designing automatic power factor correction

Power Control Circuit

Transformer

The main function of the transformer in the APFC panel is to step down the input AC 230V voltage. Then this output voltage is given to the rectifier unit.

Rectifier

The main function of the rectifier is to convert the AC voltage into the DC output. In the APFC panel we are using the bridge rectifier.

Voltage regulator

The main function of the voltage regulator is to convert the variable output DC voltage into the constant DC voltage. The U LM317 is used as a voltage regulator. It gives the two different DC supply for the working of microcontroller and LCD display.

Current transformer

The main function of the current transformer is to step down the current in a measurable value. Basically the C.T. senses the load current in the line. The part of the C.T. is its transformation ratio on which it will transform the current. These ratios are such as 100A/10A, 50A/5A, etc. then this C.T sends the signal to the microcontroller [10-12].

2.1.Design Calculation For Capacitor Size

Customer of electric power wants to increase his power factor to 0.92 to avoid paying power factor penalties that are being charged by the electrical utility. Calculate how much reactive power compensation / power factor correction they need to install to raise the power factor to 0.92 [13-14].

From table 1 we can calculate reactive and active power to go for our next design calculation part.

Total active power (P) used = 505.8 KW in previous reading

$$\begin{aligned} \text{Average} &= 505.8 / 12 \\ &= 41.15 \text{ KW} \end{aligned}$$

Total reactive power (Q) used = 544.68 KVAR in previous reading

$$\begin{aligned} \text{Average} &= 544.68 \text{ KVAR} / 12 \\ &= 45.39 \text{ KVAR} \end{aligned}$$

Total active power (P) used = 501.9 KW in present reading

$$\begin{aligned} \text{Average} &= 501.9 / 12 \\ &= 41.82 \text{ KW} \end{aligned}$$

Table 1: Data obtained from the factory

Month	Power	Previous reading	Present reading	Average power	Consumption(Wh*cost/KWh)
January	Active(W)	39168	40695	39,931.5	16,612.5
	Reactive(VAR)	47341	43433	45,387	
February	Active(W)	40695	39869	40,282	16,758
	Reactive(VAR)	37869	37896	37,882.5	
March	Active (W)	43433	48373	45,903	19,096.4
	Reactive(VAR)	53064	58254	55,659	
April	Active(W)	48256	39754	44,005	18,306.7
	Reactive(VAR)	57892	40128	49,010	
May	Active(W)	39458	40916	40,187	16,718.7

	Reactive(VAR)	38654	36782	37,718	
June	Active(W)	40824	37854	39,339	16,365.6
	Reactive(VAR)	39784	34852	27,318	
July	Active(W)	39970	48251	44,110.5	18,350.6
	Reactive(VAR)	49131	49131	49,131	
August	Active(W)	37782	38788	38,285	15,927.1
	Reactive(VAR)	46608	47847	47,227.5	
September	Active(W)	38785	39970	39,377.5	16,381.6
	Reactive(VAR)	47847	49131	48489	
October	Active(W)	40857	42191	41,524	17,274.6
	Reactive(VAR)	49131	51652	50,391.5	
November	Active(W)	42191	43433	42,812	17,810.4
	Reactive(VAR)	51652	53064	52,358	
December	Active(W)	43433	43433	43,433	18,100.9
	Reactive(VAR)	53064	53064	53,064	

Note: Block rate for all month is 0.5778.

Total reactive power (Q) used = 524.04 KVAR in present reading
 Average = 524.04 KVAR / 12
 = 43.67 KVAR

Table 2: Electrical parameter used

Supply voltage	380V
Minimum power factor	0.66
Allowed power factor	0.8
Desired power factor	0.92
Active power	41.82 KW
Frequency	50 Hz

The following step was used for design calculation;

Step1: Calculate the apparent power before corrected (S in KVA)

$$P = S \times PF \tag{1}$$

$$\begin{aligned} \text{Then, } S_{old} &= P / Pf = 41.82 \text{ KW} / 0.66 \\ &= 63.36 \text{ KVA} \end{aligned}$$

Step 2: The average reactive power from the above table calculation;

$$Q_{old} = 44.53 \text{ KVAR}$$

Step 3: Calculate new apparent power for the desired power factor (S in KVA)

$$P = S \times PF \tag{2}$$

$$\begin{aligned} S_{new} &= P / PF = 41.82 \text{ KW} / 0.92 \\ &= 45.45 \text{ KVA} \end{aligned}$$

Step 4: Calculate reactive power at desired power factor (Q_{new} in KVAR)

$$S^2 = P^2 + Q^2, \text{ then } Q^2 = S^2 - P^2 \quad (3)$$

$$(63.36 \text{ KVA})^2 = (41.82 \text{ KW})^2 + Q_{\text{new}}^2$$

$$Q_{\text{new}} = \sqrt{(45.45 \text{ KVA})^2 - (41.82 \text{ KW})^2}$$

$$= \sqrt{716.264}$$

$$Q_{\text{new}} = 17.8 \text{ KVAR}$$

Step 5: Calculate the capacitive reactive power correction needed

$$Q_{\text{old}} - Q_{\text{new}} = Q_{\text{required}} \quad (4)$$

$$Q_{\text{required}} = 44.53 \text{ KVAR} - 17.8 \text{ KVAR}$$

$$= 26.73 \text{ KVAR}$$

Hence for per phase we divide total KVAR value for three, which means reactive power required for each phase is:

$$= 26.73 \text{ KVAR} / 3$$

$$= 8.91 \text{ KVAR}$$

From the above calculation the total current before capacitor added is calculated as follows

$$\text{Apparent power} = V_{\text{rms}} \times I_{\text{rms}} \quad (5)$$

$$I_{\text{rms}} \text{ of the } S_{\text{new}} = 45.45 / 380\text{V}$$

$$= 119.6 \text{ A}$$

$$\text{Active component of } I_{\text{active}} = I_{\text{rms}} \cos \phi$$

$$= 119.6 \text{ A} \times 0.66$$

$$= 78.93 \text{ A}$$

Reactive component of current

$$I_{\text{old reactive}} = I_{\text{rms}} \sin \phi, \text{ first let we find } \phi \text{ value.}$$

$$\phi = \cos^{-1}(0.66) = 48.7 \text{ degree}$$

$$\sin(48.7) = 0.75,$$

$$\text{then reactive component of } I_L = I \sin \phi = 119.6 \text{ A} \times 0.75 = 89.7 \text{ A}$$

The new Reactive component of the current is equal to;

$$I_{\text{new reactive}} = I_{\text{rms}} \sin \phi$$

$$\text{but } \cos^{-1}(0.92) = 23.07 \text{ degree, so } \sin \phi = 0.392$$

$$= 119.6 \text{ A} \times 0.392 = 46.88 \text{ A}$$

Therefore to connect the capacitor bank in star connection the capacitor line current is calculated from the difference of corrected reactive current from uncorrected reactive current.

$$I_C = I_{\text{old reactive}} - I_{\text{new reactive}} = 89.7 \text{ A} - 46.88 \text{ A}$$

$$= 42.82 \text{ A}$$

Per phase capacitor current (I_{CP}) = I_C = 42.82 A

$$I_{CP} = V_{\text{ph}} / X_C = 2\pi f c V_{\text{ph}} \text{ Where } V_{\text{ph}} \text{ is equal to } \sqrt{3} \text{ times line voltage}$$

$$C = I_{cp} / 2\pi f V_{\text{ph}} = 42.82 \text{ A} / 2\pi \times 50\text{Hz} \times \sqrt{3}(380\text{V})$$

$$= 207.09 \times 10^{-6} \text{ F}$$

Therefore each capacitor value can be 69.03×10^{-6} Farad

To calculate capacitive reactance;

$$\text{Therefore } X_C = 1 / 2\pi f c$$

$$= 1 / 2\pi \times 50 \times 207.09 \times 10^{-6} \text{ Farad}$$

$$= 15.37 \Omega$$

Step 6: To calculate the inductive reactance the first thing is; we have to solve for inductor, as we have.

$$X_L = Q / I_{\text{rms}}^2 = 17.8 \text{ KVAR} / (119.6)^2$$

$$\begin{aligned}
 &= 1.24 \Omega \\
 \text{Inductance, } L &= \frac{XL}{2\pi \times f} \\
 L &= 1.24 \Omega / 2\pi \times 50 \text{ Hz} \\
 &= 3.97 \times 10^{-3} \text{ H}
 \end{aligned}
 \tag{6}$$

We have the following for protection of capacitor bank;

Fuse

Size of the fuse = 165% to 200% of Capacitor Charging current.
 Size of the fuse = $1.85 \times 42.82 \text{ A}$
 Size of the fuse = 79.2 A

Circuit Breaker

The circuit breaker should be sized no less than 135% of the rated capacitor current:
 Rated Capacitor Current = $(Q_{\text{new}} / \text{Voltage}) \text{ Amps}$
 Rated Capacitor Current = $(17.8 \times 1000) / 380\text{V}$
 = 46.84 A

The breaker shall be rated to carry the current equal to 78.42 A x 135% or 63.2 A continuously in its operating environment.

Contactors for Capacitors Switching

An automatic power factor correction system consists of several capacitor banks of identical or different ratings (several steps), energized separately according to the value of the power factor to be corrected. An electronic device automatically determines the power of the steps to be energized and activates the relevant contactors. The inrush current peak, in the case of automatic correction, depends on the power of the steps already on duty, and can reach 100 times the nominal current of the step to be energized.

$$\begin{aligned}
 I_1 &= 17.8 \text{ KVAR} / \text{V} \\
 I_1 &= 17.8 \text{ KVAR} / 380\text{V} = 46.8 \text{ A}
 \end{aligned}$$

The contactor operating currents $I_e = 46.8 \text{ A}$ then the selected contactors' have to carry capacity of 46.8 A

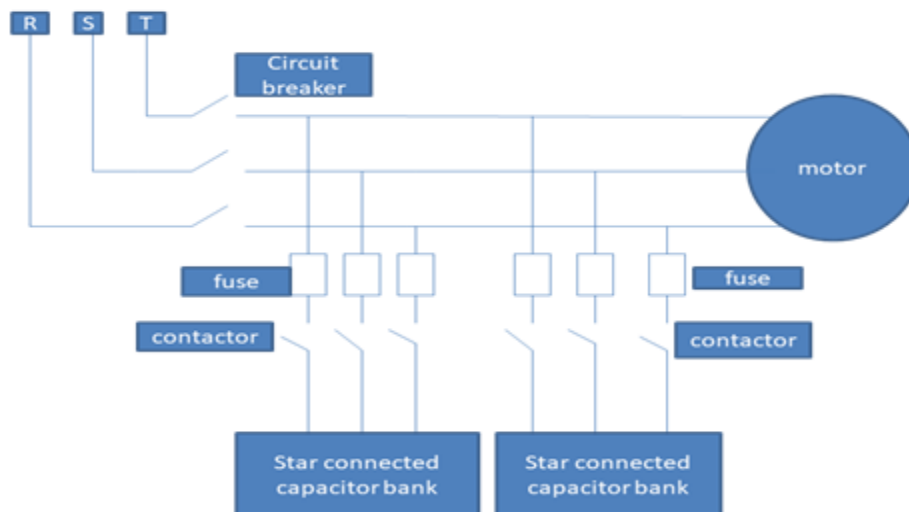

Figure 3: Over all capacitor bank protection circuit

2.2. Cost Analysis

To calculate the cost paid before corrected and after corrected we have as follows. The cost paid per KVA is 0.67 birr analyzed from the gathered data.

Before Corrected

S = 63.36 KVA per month

Per month payment = 0.67birr/KVA x 63.36 KVA = 42.45 birr/month

Per year payment = 594.41 birr

After Corrected

S = 44.53 KVA per month

Per month payment = 44.53 KVA x 0.67 birr/KVA = 29.83 birr/month

Per year payment = 358.02 birr

Saved birr = Before corrected per year – After corrected per year

Saved birr = 236.38 birr

Table 3: before corrected and after corrected data

No.	Status	Birr
1	Before corrected	594.41
2	After corrected	358.02
3	Saved	236.38

3. Results and Discussions

3.1. The Development

The overall system designed for automatic power correction is shown according to the circuit diagram blow.

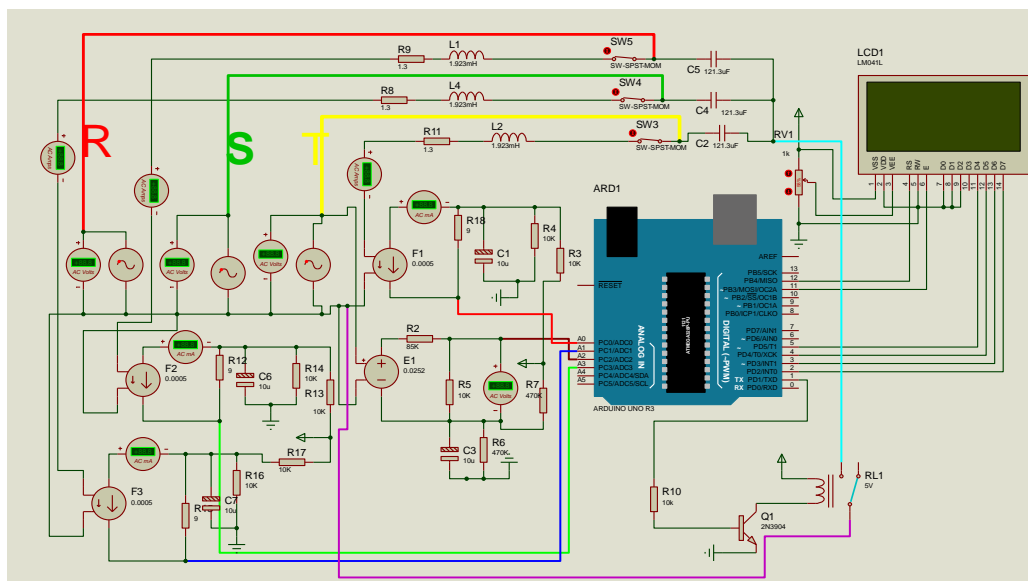

Figure 4: Over all designed circuit

3.2. Power Supply

The input supply 220V AC is given to the primary of the transformer (Transformer is an electromechanical static device which transform one coil to another without changing its frequency) due to the magnetic effect of the coil the flux is induced in the primary is transfer to the secondary coil. The output of the secondary coil is given to the diodes. Here the diodes are connected in bridge type. Diodes are used for rectification purposes. The output of the bridge circuit is not pure dc, somewhat rippled ac is also present. For that capacitor is connected at the output of the diodes to remove the unwanted ac, capacitor are also used for filtering purpose.

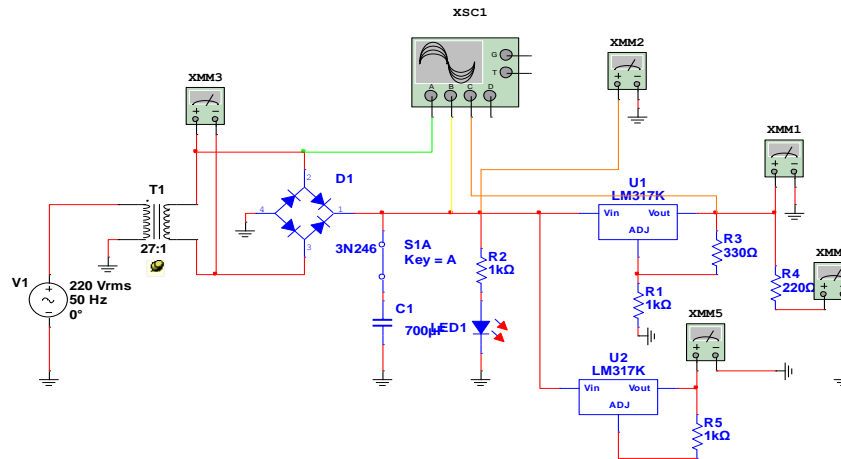

Figure 5: Power control circuit simulation

3.3. CT and VT Connection Diagram

In this part of the designed circuit the VT (voltage transformer) and CT (current transformer) are used to control our voltage before entering the arduino microcontroller ATmega 328 through the pin1 and pin 0. In this case the 380V stepped down and controlled to 5V which is given for microcontroller. The resistor is used to shift the voltage level.

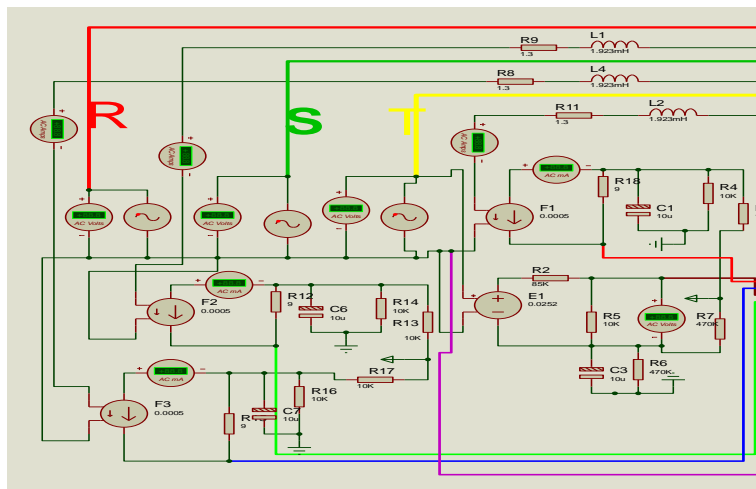

Figure 6: Current and voltage transformer circuit

3.4. Relay

The load capacity found in the industry were not constant i.e. May be varied from time to time, for that case relay used as feedback when the load capability is changed i.e. the relay is out off function at normal load level but closed when capacity of load increase to keep our power factor efficient.

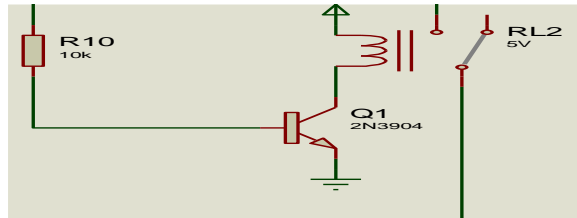

Figure 7: Relay circuit diagram

3.5.The Simulation

An automatic power factor correction is the principle based on the automatic to develop that the circuit blow is designed to perform the automatic operation. In the industrial application there is the time when load is increased, at that time the system may affected because lose. This is the reason why power factor is low, to overcome this when the load is added the relay is activated. The relay activated performs operation automatically to input the capacitor bank into the system. The inductive loads are connected in parallel with in each other and capacitor bank protection is connected in parallel with that inductive load. The microcontroller used to read the current and voltage level for determining our power as well as power factor. The RV1 is used to adjust the colour of the liquid crystal display. The arduino ATmega 328 microcontroller is used to read analog input and convert it into digital from the input data as it programmed. Then the liquid crystal display, display the result it get from the microcontroller. The analog input for the microcontroller voltage input at pin1 and current input at pin 0. The transistor used as a switch in this design is connected to digital output pin 1. The digital output given to the LCDs are pin 11, pin 12, pin 13, pin 14, pin 6, and pin 4.

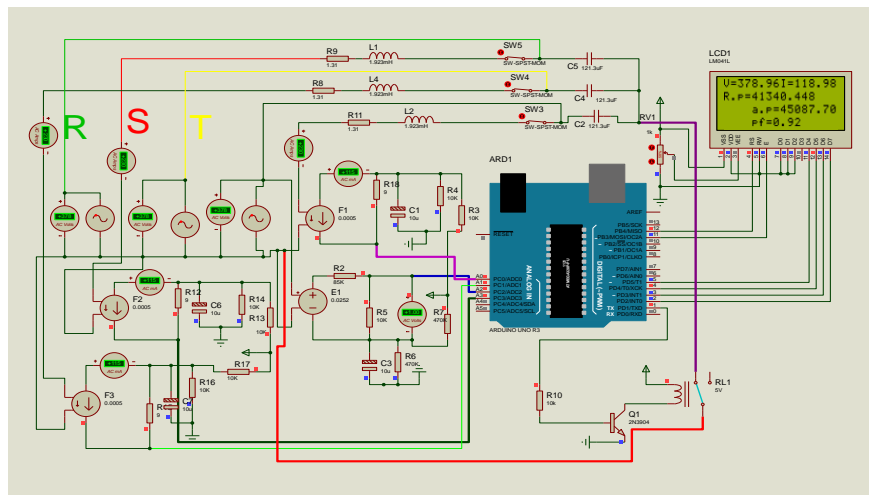

Figure 8: Over all designed circuit simulation result

4. Conclusions

In Ethiopia there is no shortage of power except that there is a problem with use of power in effective way. Now this work, design and simulation of automatic power factor corrector address the problem of low power corrector and overcome the problem in order to make customer free of penalty. The automatic power factor correction device is a very useful device for improving efficient transmission of active power. So it can be concluded that power factor correction technique can be applied to the industries, power system, and also house hold to serve them with stable way and due to that the system become stable. Efficiency of the system as well as apparatus increases. The role of automatic power factor corrector is to reduce cost, reduce development time, low power supply and low data rate. Totally this paper accomplishes an aim of the design as it shown on the simulated diagram of corrected output of power factor.

References

- [1] M.H.Rashid,"Power Electronics: Circuits, Devices, and Applications", Englewood Cliffs, N.J.Prentice-Hall, 1998.
- [2] K.K.Sum, "Recent Development in Resonant Power Conversion", Calif; Intertech Communications, 1988
- [3] "Unitrode Switching Regulated Power Supply Design Seminar", Lexington, Mass, Unitrode Corporation, 1994.
- [4] Tim Dessay, Samuel Dessay. "Teach yourself Electronic and Electricity", June 1993.
- [5] Rohta Mehta,"Principle of Power System", V.K.mehta, 1982.
- [6] O.Gacia J.A.Cobos, R.Prieto, P.Alou, J.Uceda,"Single Phase Power Factor Correction", may 2007.
- [7] John J.Grainger,Wiliam D.Stevenson."Power System Analysis", New York, Mc Graw-Hill, 1994.
- [8] Meir, Alexandra. "Electric Power System: A Conceptual Introduction", S.L Willey-IEEE press, 2006.
- [9] J.Sebastian, M. Jaureguizar and J.Uceda. "An Overview of Power Factor Correction in Sngle Phase", june 2008.
- [10] Kepka, Jakob and Wroclaw. "Power Factor Correction- Design of Automatic Capacitor Bank", oct.2010.
- [11] "Off-line Power Supply Systems", IECON'94, IEEE Trans. Power Electron. Vol 3, pp1688-1693, May 2003.
- [12] Z.Lai and K.smedley."A Family of Power Factor Correction Controllers", IEEE Trans. Power Electron, vol 13, Issue 3, pp 501-510, May 1998.
- [13] [Http://WWW.electtricitytechnology.org/2013/11/how-to-calculate-suitable-capacitor size-for-power-factor- improvement.html](http://WWW.electtricitytechnology.org/2013/11/how-to-calculate-suitable-capacitor-size-for-power-factor-improvement.html).
- [14] J. Dungan Glover, Mulukts S.Sarma, Thomas G. Overbye."Power System Analysis and Design", Fifth edition, sebt 1997.

*Corresponding author.

E-mail address: ararsotaye@ yahoo.com